

SERVICE & PARTS MANUAL - ELECTRIC SCISSOR TABLE

MODEL SC-450-D-E / SC2450

IMPORTANT NOTICE

PLEASE PASS THIS LEAFLET TO YOUR SAFETY OFFICER BEFORE USE AND KEEP IT IN A SAFE PLACE.

READ THOROUGHLY BEFORE USE AND FAMILIARISE YOURSELF WITH THE TRUCK AFTER READING THESE INSTRUCTIONS.

TEST CERTIFICATES SHOULD BE PASSED TO THOSE RESPONSIBLE FOR YOUR REGISTER OF LIFTING EQUIPMENT AND BE RETAINED FOR SCRUTINY BY A FACTORY INSPECTOR, INSURANCE COMPANY ETC.

NO LIFTING GEAR SHOULD BE PUT INTO USE WITHOUT A VALID TEST CERTIFICATE, NOR USED BY UNTRAINED STAFF WHO ARE NOT FULLY AWARE OF THE INSTRUCTIONS FOR SAFE USE.

TECHNICAL DETAILS SC-450-D-E

BUILT TO:	EN 1570
MAX CAPACITY:	450 kg
TOP SIZE:	610 mm x 1030 mm
CLOSED HEIGHT:	295 mm
RAISED HEIGHT:	1550 mm
HANDLE HEIGHT:	910 mm
SOUND LEVEL:	78 db

HANDLING

This product weighs 175 kg. There are no special handling requirements. Do not invert table or put on its side.

SAFETY

This table has been built to BS 5323 and every table is accompanied by a Test Certificate. **Please** read and **keep** it in a safe place. You may be asked to present it by your insurance company or factory inspector. For safety the table has been designed to give:-

- 30mm gap between the arms.
- 50mm gap between the arms and frame.
- Flow control cartridge in ram. Even if the hydraulic hose is cut the table will still descend at a safe speed.

IT IS DANGEROUS TO WORK UNDER THE TABLE TOP WHEN THE PLATFORM IS IN THE RAISED POSITION

ONLY AUTHORISED PERSONS SHOULD BE ALLOWED TO OPERATE THIS TABLE

ANY DAMAGE, OR IF THE TABLE DOES NOT PERFORM CORRECTLY, SHOULD BE REPORTED IMMEDIATELY AND DISCONTINUE USE.

This table is fitted with a safety cut off bar. Should the bar hit an obstruction when lowering, the table will stop lowering immediately.

ASSEMBLY

This product is normally assembled before delivery.

UNFORESEEN USE

- **DO NOT** use on ramps or slopes
- **ALWAYS** check for damage
- **DO NOT** use if damaged
- **DO NOT** work under the table top in the raised position
- **DO NOT** remove warning labels
- **DO NOT** lift more than the rated capacity
- **ALWAYS** apply the brake when stationary
- **ENSURE** people are clear of the table before lowering
- **DO NOT** use with the charger connected
- **DO NOT** use with battery cover removed
- **DO NOT** smoke in the area when the battery is being charged

Please note, we strongly advise against the use of this product in wet or damp conditions. If you do need to use this product in a wet or damp environment, please contact Customer Service.

LOADING THE TABLE TOP

This table has been manufactured and tested to take the full load spread over the table top. Half the load over half the platform length, one third of the load over one half of its width. **This loading must not be exceeded.**

MAINTENANCE CHECKS & ADJUSTMENTS

With table fully lowered, the top hinges to allow access to the mechanism. All hinged points have nylon bearings and the ball races are sealed, therefore, little maintenance should be required.

Daily: The machine should be checked daily by the operator for obvious damage and oil leaks. Faults should be reported.

Monthly: Check the oil for serious oil leaks (with hydraulic units some oil may escape around the cylinder which lubricates the seal, if in doubt check with engineer). Check that the brake is in working order.

Annually: The table should be re-tested.

CHARGING

The scissor table is provided with a separate electronic battery charger and this should be used to top up the battery charge regularly. The interval depends upon the extent of use.

CHARGER

- Supply 220/240 Volt 50 Hz 85 Watts
- Protected by automatic breaker
- Use 6 Amp fuse
- Outputs 4 Amp 12 Volt (6 Amp R.M.S.)

PROCEDURE FOR CHARGING

PLEASE OBSERVE NORMAL SAFETY PRECAUTIONS WHEN CHARGING BATTERIES

1. Connect the battery charger plug to the white socket on top of the electric box.
2. Switch on the battery charger.
3. Leave to charge.
4. Switch off the battery charger.
5. Disconnect the charger from the battery.

IMPORTANT NOTES

The scissor table should not be used during charging
The battery cannot be overcharged if the electronic charger supplied is used

OPERATING INSTRUCTIONS

Control: The electric pump and hydraulic circuits are controlled via a push button remote switch.

FILLING WITH OIL

The hydraulic pump is filled with TELLUS 22 or ISO VG22 equivalent. It will be necessary to top up the hydraulic oil occasionally via the filler. Only fill with enough oil to allow the table to lift to full height - overfilling will cause leakage.

To top up with oil, adjust the mechanism or work on any part of the pump, the table should be completely lowered and the top hinged back for access to the hydraulic systems.

SPARE PARTS – INITIAL EMERGENCY SPARES

QTY	PART NO	DESCRIPTION
2	WH20-312	Braked Castor Bracket
2	WH20-210	Poly wheel (castor)
1	OL18	Bottle of hydraulic oil
1	HY474	Ram Seal Kit
2	WH20-407	Poly fixed wheel

IMPORTANT: When ordering spare parts please specify the model, serial number and capacity.

FAULT FINDING CHART

FAULT	REMEDY
Will not lift	Check that battery is fully charged. Check battery terminal.
If fault remains	Check oil level. This should be 20 mm below filler in lowered position.
If fault remains	Check lead from battery to motor

POWER PACK

ITEM	PART NO	QTY	ITEM	PART NO	QTY
2	HY442	1	12	HY590	1
6	HY435	1	13	E-598	2
8	E-591	1	14	E-593	1
9	PH40-585	1	15	F40-584	1
10	E-652	2	16	E-651	1

Charger ET-CH-003 EURO PLUG
ET-CH-004 UK PLUG

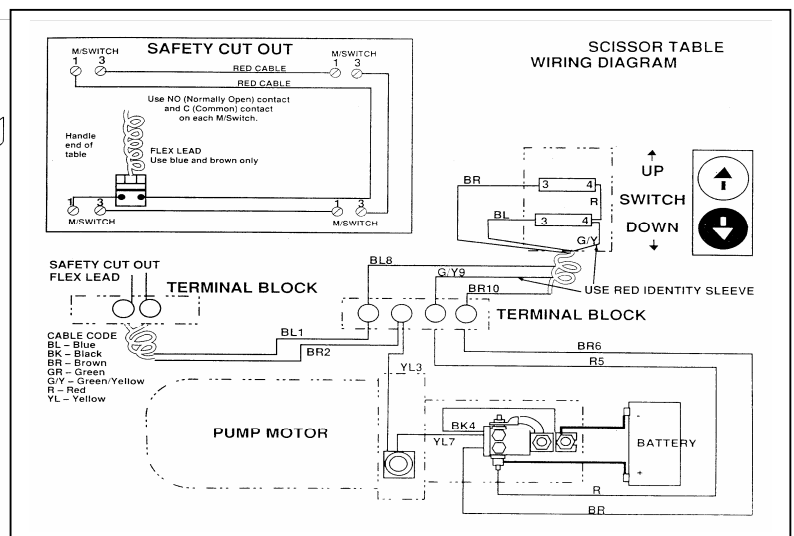
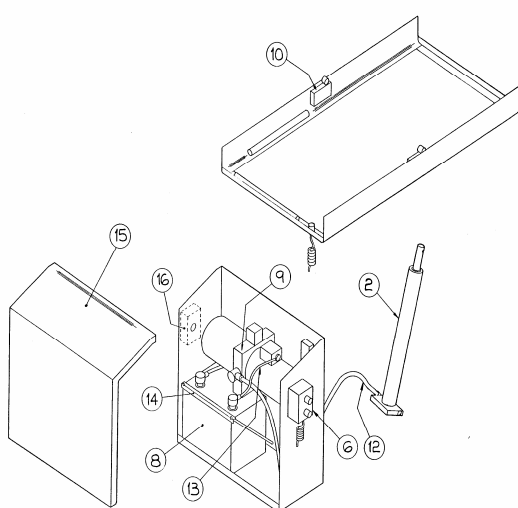

FRAME

ITEM	QUANTITY	PART NUMBER
100	1	F20-286
101	1	F20-290
102	1	F20-287
104	2	WH20-312
105	1	F20-279
106	2	WH20-407
107	4	BE10-071
109	1	HY466

